

# Delta robot: inverse, direct, and intermediate Jacobians

M López<sup>1\*</sup>, E Castillo<sup>2</sup>, G García<sup>3</sup>, and A Bashir<sup>4</sup>

<sup>1</sup>Centro de Ingeniería y Desarrollo Industrial, Querétaro, México

<sup>2</sup>Universidad Autónoma de Querétaro, Centro Universitario, Querétaro, México

<sup>3</sup>Instituto Tecnológico de Morelia, Michoacán, México

<sup>4</sup>Universidad Michoacana de San Nicolás de Hidalgo, Ciudad Universitaria, Michoacán, México

*The manuscript was received on 26 November 2004 and was accepted after revision for publication on 11 October 2005.*

DOI: 10.1243/095440606X78263

**Abstract:** In the context of a parallel manipulator, inverse and direct Jacobian matrices are known to contain information which helps us identify some of the singular configurations. In this article, we employ kinematic analysis for the Delta robot to derive the velocity of the end-effector in terms of the angular joint velocities, thus yielding the Jacobian matrices. Setting their determinants to zero, several undesirable postures of the manipulator have been extracted. The analysis of the inverse Jacobian matrix reveals that singularities are encountered when the limbs belonging to the same kinematic chain lie in a plane. Two of the possible configurations which correspond to this condition are when the robot is completely extended or contracted, indicating the boundaries of the workspace. Singularities associated with the direct Jacobian matrix, which correspond to relatively more complicated configurations of the manipulator, have also been derived and commented on. Moreover, the idea of intermediate Jacobian matrices have been introduced that are simpler to evaluate but still contain the information of the singularities mentioned earlier in addition to architectural singularities not contemplated in conventional Jacobians.

**Keywords:** parallel manipulators, singular configurations, Jacobian analysis

## 1 INTRODUCTION

Theoretical and practical progress in the field of parallel manipulators has speeded up enormously over the last 20 years. The underlying reasons are that these mechanisms are stronger, faster, and more accurate. They are capable of accelerating up to 50 g, lifting several tonnes in seconds, and moving with a precision of nano meters. As a result, their impact on various industries with objectives ranging from food packaging to flight simulations is enormous. However, parallel robots can have their own problems and not all of these have been solved. New topologies are being continuously proposed to improve their working. Earlier studies were focused on parallel mechanisms with six degrees of freedom (DOF) that carry the advantage of high stiffness, low inertia, and large payload capacity. However,

they suffer from the problems of relatively small useful workspace and design difficulties. Moreover, overwhelming problems exist for finding closed-form expressions for direct kinematics. In order to avoid these problems, there has been recently a growing tendency to focus on parallel manipulators with three translational DOF, which are better-suited for high speed and high stiffness manipulation. Moreover, the availability of closed-form solutions enables accurate design and efficient control. A widely known example is the one designed by Clavel [1], generally referred to as the Delta robot. It is a perfect candidate for pick and place operations of light objects. Since the advent of the company Demarex, Delta robots of varying dimensions have been introduced into a large variety of industrial markets, e.g. food, pharmaceutical, and electronics industries. For a detailed review of its industrial applications, see reference [2]. Since then, several other proposals have been put forward in the literature [3–8]. In this article, the focus of study is the Jacobian analysis of the Delta robot.

\*Corresponding author: Centro de Ingeniería y Desarrollo Industrial, Av. Pie de la Cuesta No. 702, Desarrollo San Pablo, C. P. 76130 Santiago de Querétaro, Querétaro, México.

The traditional Jacobian matrix provides a transformation from the velocity of the end-effector in Cartesian space to the actuated joint velocities [9]. When a manipulator is at a singular position, the Jacobian matrix is singular too [10, 11]. In the case of the parallel manipulators, it is convenient to work with a two-part Jacobian [10], the inverse and the forward one. The advantage is that a two-part Jacobian allows, in a natural way, the identification as well as classification of various types of singularities. Following closely the technique presented by Stamper [12], the inverse and forward Jacobian matrices for the Delta robot are evaluated. [13, 14] The classification scheme outlined by Gosselin and Angeles [10], then allows us to categorize the singularities of the Delta robot into three types. The first type corresponds to the situation where different branches of the inverse kinematics problem converge. This type of singularity results in a loss of mobility and occurs at the boundary of the manipulator workspace. The second type is realized when different branches of the forward kinematics problem converge, resulting in additional DOF at the end-effector. Simultaneous occurrence of these two kinds can be classified as the third type of singularity [15]. Additionally, there also exist architectural singularities, e.g. when the dimensions of the moving and fixed platforms are comparable. Therefore, special care should be taken in the design of these manipulators to avoid the said singularities. It is found that these singularities by reducing a certain number of legs from the full kinematic chain and carrying out a Jacobian analysis for the reduced loop. The corresponding Jacobians are termed as the intermediate Jacobians.

This paper is organized as follows: section 2 is devoted to a brief review of the kinematic analysis to establish the notation. Based upon the equations presented in section 2, the derivation of the two Jacobians are carried out in section 3. In section 4, the singularity analysis is presented. Section 5 introduces a simpler technique of identifying singularities based upon intermediate Jacobians. Section 6 concludes the article.

## 2 KINEMATICS

The Delta robot consists of a moving platform connected to a fixed base through three parallel kinematic chains. Each chain contains a rotational joint activated by actuators in the base platform. The movements are transmitted to the mobile platform through parallelograms formed by bars and spherical joints, Fig. 1.

The kinematics of the Delta robot can be studied by analysing Fig. 2, where O represents the centre

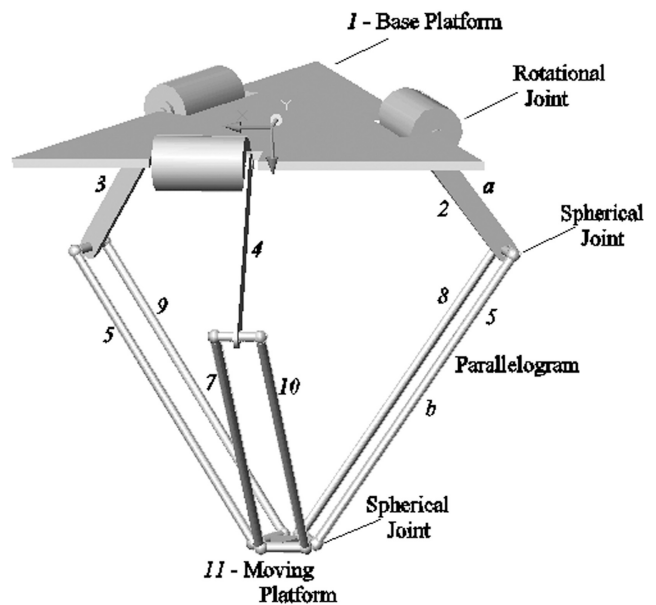

Fig. 1 The Delta robot 580

of the fixed platform and  $A_i$  three points on the middle of the three sides of the fixed platform.

These are the points where the limbs hold onto the platform and correspond to the position of the actuators. P is the centre of the moving platform. Two convenient sets of Cartesian co-ordinate frames,  $xyz$  and  $x_i y_i z_i$ , are defined in such a way that the  $xy$ -plane and the  $x_i y_i$ -plane are the same and coincide with the plane of the fixed platform. Axes  $z$  and  $z_i$  are perpendicular to the above planes and, therefore, are identical. The angle between  $x$ -axis, i.e.  $Ox$ , and the  $x_i$ -axis, i.e.  $Ox_i$ ,  $OA_i$ , or  $A_i x_i$ , is  $\phi_i$ .  $OA_i$  is always parallel to  $PC_i$ . Owing to the presence of the rotational joint at  $A_i$ ,  $A_i B_i$  moves just in the  $x_i z_i$ -plane. At  $B_i$  are passive spherical joints. So  $B_i C_i$  can have components along all the three axes, namely  $A_i x_i$ ,  $A_i y_i$ ,

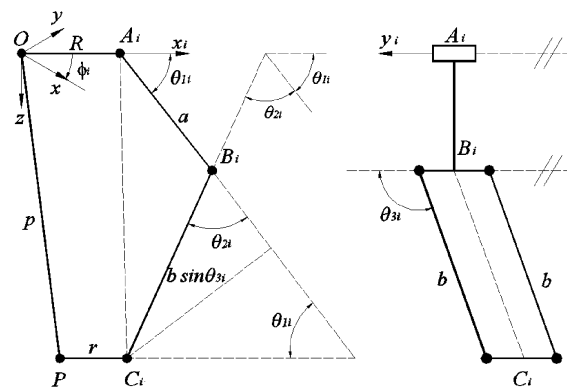

Fig. 2 The left half shows the projection of the Delta robot onto the  $x_i z_i$ -plane and helps in defining some kinematic variables. The right half shows the end-on view

and  $A_i z_i$ .  $\theta_{1i}$  is the angle between  $A_i B_i$  and  $A_i x_i$ .  $\theta_{2i}$  is the angle between  $A_i B_i$  and the line that results from the intersection of the planes  $x_i z_i$  and that of the parallelogram shown on the right half of Fig. 1. Therefore, this line lies in the  $x_i z_i$ -plane.  $\theta_{3i}$  is the angle between  $B_i C_i$  and  $A_i y_i$ . As a result,  $b \cos \theta_{3i}$  is the component of  $B_i C_i$  parallel to  $A_i y_i$  and  $b \sin \theta_{3i}$  is the component of  $B_i C_i$  in the  $x_i z_i$ -plane.

The most relevant loop should be picked up for the intended Jacobian analysis. Let  $\vec{\theta}$  be the vector made up of actuated joint variables and  $\vec{p}$  be the position vector of the moving platform. Then

$$\vec{\theta} = \theta_{1i} = \begin{bmatrix} \theta_{11} \\ \theta_{12} \\ \theta_{13} \end{bmatrix}, \vec{p} = \begin{bmatrix} p_x \\ p_y \\ p_z \end{bmatrix} \quad (1)$$

The Jacobian matrix will be derived by differentiating the appropriate loop closure equation and rearranging the result in the following form

$$J_\theta \begin{bmatrix} \dot{\theta}_{11} \\ \dot{\theta}_{12} \\ \dot{\theta}_{13} \end{bmatrix} = J_p \begin{bmatrix} \dot{p}_x = v_x \\ \dot{p}_y = v_y \\ \dot{p}_z = v_z \end{bmatrix} \quad (2)$$

where  $v_x$ ,  $v_y$ , and  $v_z$  are the  $x$ ,  $y$ , and  $z$  components of the velocity of the point P on the moving platform in the  $xyz$  frame. In order to arrive at the above form of the equation, we look at the loop  $OA_i B_i C_i P$ . The corresponding closure equation in the  $x_i y_i z_i$  frame is

$$\vec{OP} + \vec{PC}_i = \vec{OA}_i + \vec{A_i B_i} + \vec{B_i C_i} \quad (3)$$

In the matrix form we can write it as

$$\begin{bmatrix} p_x \cos \phi_i - p_y \sin \phi_i \\ p_x \sin \phi_i + p_y \cos \phi_i \\ p_z \end{bmatrix} = \begin{bmatrix} R \\ 0 \\ 0 \end{bmatrix} - \begin{bmatrix} r \\ 0 \\ 0 \end{bmatrix} + a \begin{bmatrix} \cos \theta_{1i} \\ 0 \\ \sin \theta_{1i} \end{bmatrix} + b \begin{bmatrix} \sin \theta_{3i} \cos (\theta_{2i} + \theta_{1i}) \\ \cos \theta_{3i} \\ \sin \theta_{3i} \sin (\theta_{2i} + \theta_{1i}) \end{bmatrix} \quad (4)$$

Time differentiation of this equation leads to the desired Jacobian equation as shown in the next section.

### 3 THE JACOBIAN MATRICES

The loop closure equation (3) can be re-written as

$$(\vec{p} + \vec{r}) = \vec{R} + \vec{a}_i + \vec{b}_i \quad (5)$$

Differentiating this equation with respect to time and using the fact that  $\vec{R}$  is a vector characterizing the fixed platform

$$\underbrace{\frac{d}{dt}(\vec{p} + \vec{r})}_{\dot{\vec{p}}} = \dot{\vec{a}}_i + \dot{\vec{b}}_i$$

In this expression, every point on the moving platform has exactly the same velocity. Therefore

$$\dot{\vec{p}} = \vec{v} = \dot{\vec{a}}_i + \dot{\vec{b}}_i \quad (6)$$

The linear velocities on the right hand side of equation (6) can be readily converted into the angular velocities by using the well-known identities. Thus

$$\vec{v} = \vec{\omega}_{a_i} \times \vec{a}_i + \vec{\omega}_{b_i} \times \vec{b}_i \quad (7)$$

The presence of  $\vec{\omega}_{b_i}$  introduces an awkward dependence upon the variables  $\dot{\theta}_{2i}$  and  $\dot{\theta}_{3i}$ . However, there is a way out. It can be got rid of by taking a scalar product of expression (7) with the unit vector  $\hat{b}_i$

$$\hat{b}_i \cdot [\vec{v} = \vec{\omega}_{a_i} \times \vec{a}_i + \vec{\omega}_{b_i} \times \vec{b}_i]$$

As the triple product with two identical vectors is zero, what is left is merely

$$\hat{b}_i \cdot \vec{v} = \hat{b}_i \cdot \vec{\omega}_{a_i} \times \vec{a}_i \quad (8)$$

In the component form, the left-hand side of this equation can be written as

$$\begin{aligned} \hat{b}_i \cdot \vec{v} &= [\sin \theta_{3i} \cos (\theta_{2i} + \theta_{1i})][v_x \cos \phi_i - v_y \sin \phi_i] \\ &\quad + \cos \theta_{3i}[v_x \sin \phi_i + v_y \cos \phi_i] \\ &\quad + [\sin \theta_{3i} \sin (\theta_{2i} + \theta_{1i})]v_z = J_{ix}v_x \\ &\quad + J_{iy}v_y + J_{iz}v_z \end{aligned} \quad (9)$$

where

$$\begin{aligned} J_{ix} &= \sin \theta_{3i} \cos (\theta_{2i} + \theta_{1i}) \cos \phi_i + \cos \theta_{3i} \sin \phi_i \\ J_{iy} &= -\sin \theta_{3i} \cos (\theta_{2i} + \theta_{1i}) \sin \phi_i + \cos \theta_{3i} \cos \phi_i \\ J_{iz} &= \sin \theta_{3i} \sin (\theta_{2i} + \theta_{1i}) \end{aligned} \quad (10)$$

On the right-hand side of equation (8), the movement of the joint  $a$  is in the  $x_i z_i$ -plane. Thus it only has a component of velocity in this plane. This is

the angular velocity about the  $y$  axis. Thus

$$\vec{\omega}_{a_i} = \begin{bmatrix} 0 \\ -\dot{\theta}_{1i} \\ 0 \end{bmatrix} \quad (11)$$

The negative sign is just a matter of convention. Therefore

$$\vec{\omega}_{a_i} \times \vec{a}_i = \begin{vmatrix} \hat{i} & \hat{j} & \hat{k} \\ 0 & -\dot{\theta}_{1i} & 0 \\ a_{1i} & a_{2i} & a_{3i} \end{vmatrix} = -a_{3i} \dot{\theta}_{1i} \hat{i} + a_{1i} \dot{\theta}_{1i} \hat{k}$$

The right-hand side of equation (8) can now be written in its simplified form as

$$\hat{b}_i \cdot (\vec{\omega}_{a_i} \times \vec{a}_i) = -a \sin \theta_{2i} \sin \theta_{3i} \dot{\theta}_{1i} \quad (12)$$

The equations (9) and (12) can be equated for every value of  $i$

$$J_{1x}v_x + J_{1y}v_y + J_{1z}v_z = -a \sin \theta_{21} \sin \theta_{31} \dot{\theta}_{11}$$

$$J_{2x}v_x + J_{2y}v_y + J_{2z}v_z = -a \sin \theta_{22} \sin \theta_{32} \dot{\theta}_{12}$$

$$J_{3x}v_x + J_{3y}v_y + J_{3z}v_z = -a \sin \theta_{23} \sin \theta_{33} \dot{\theta}_{13}$$

which readily implies

$$J_p \vec{v} = J_\theta \dot{\vec{\theta}} \quad (13)$$

where

$$J_p = \begin{bmatrix} J_{1x} & J_{1y} & J_{1z} \\ J_{2x} & J_{2y} & J_{2z} \\ J_{3x} & J_{3y} & J_{3z} \end{bmatrix} \quad (14)$$

and

$$J_\theta = a \times \begin{bmatrix} \sin \theta_{21} \sin \theta_{31} & 0 & 0 \\ 0 & \sin \theta_{22} \sin \theta_{32} & 0 \\ 0 & 0 & \sin \theta_{23} \sin \theta_{33} \end{bmatrix} \quad (15)$$

## 4 THE SINGULARITIES

The singularities of the manipulator are obtained by encountering the conditions that yield singular Jacobian matrices. The two-part Jacobian helps in the classification of these singularities.

### 4.1 Inverse kinematic singularities

The inverse kinematic singularities are associated with the inverse Jacobian and they arise when

$$\det(J_\theta) = 0 \quad (16)$$

As is well known, the physical significance of this condition becomes obvious if the equation (13) is written as follows

$$\dot{\vec{\theta}} = J_\theta^{-1} J_p \vec{v} = \frac{Adj(J_\theta)}{\det(J_\theta)} J_p \vec{v}$$

Since the velocities cannot be infinitely large, the condition  $\det(J_\theta) = 0$  must imply  $\vec{v} = 0$  in some direction. Thus there exist some non-zero  $\dot{\vec{\theta}}$  vectors that produce  $\vec{v}$  vectors that are zero in some direction, i.e. there are moving platform velocities that cannot be achieved. This happens at the boundary of the workspace. Equation (16) implies

$$\theta_{2i} = 0 \text{ or } \pi \quad \text{for any of the } i \quad (17)$$

or

$$\theta_{3i} = 0 \text{ or } \pi \quad \text{for any of the } i \quad (18)$$

1. Condition (17) corresponds to the configuration when the limb  $a_i$  is in the plane of the parallelogram formed by limb  $b_i$  for any of the  $i$ .
2. Condition (18) corresponds to the posture when any of the limbs  $b_i$  is parallel (or anti-parallel) to  $y$ -axis. As  $a_i$  is in the  $xz$ -plane, it means that in this configuration,  $a_i \perp b_i$ .

For example, the completely stretched out posture of the robot tends to make all  $a_i$  parallel to  $b_i$ . On the other hand, a completely contracted position tries to force  $a_i$  and  $b_i$  anti-parallel to each other. These positions of the manipulator correspond to the lower and upper boundaries of the workspace and have been depicted in Figs 3 and 4. Note that in practice,  $a_i$  and  $b_i$  cannot become completely anti-parallel because of the mechanical restrictions imposed by the rotational joints possessing a finite size.

### 4.2 Direct kinematic singularities

The direct kinematic singularities are related to the singularities of the direct Jacobian given in equation (14), which is much more complicated than the inverse Jacobian. Recalling that the determinant of a Jacobian vanishes when any row or any column is identically zero, a representative example of a

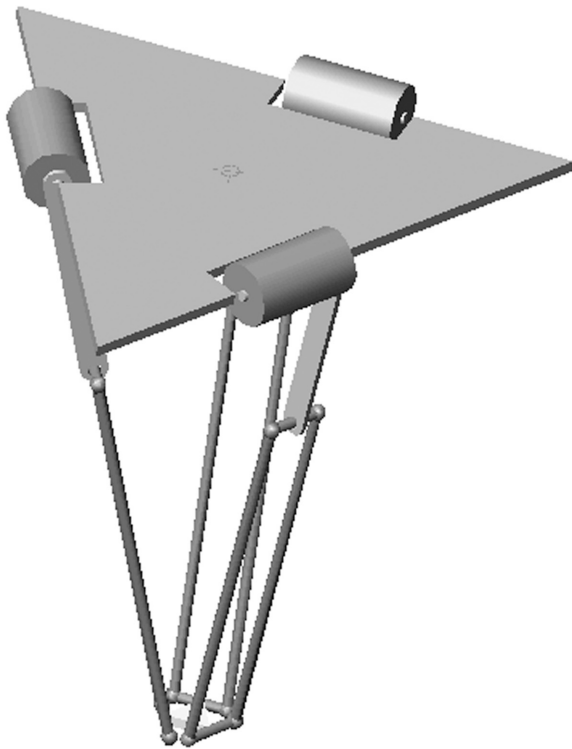

**Fig. 3** Completely stretched out posture of the robot depicting condition (17)

couple of singular configurations is provided next

$$\theta_{3i} = 0 \text{ or } \pi \forall i \quad (19)$$

or

$$\theta_{2i} + \theta_{1i} = 0 \text{ or } \pi \forall i \quad (20)$$

1. Condition (19) implies that the third column of  $J_p$  is zero. Physically, the posture of the robot corresponds to when all the limbs  $b_i$  are in the plane of

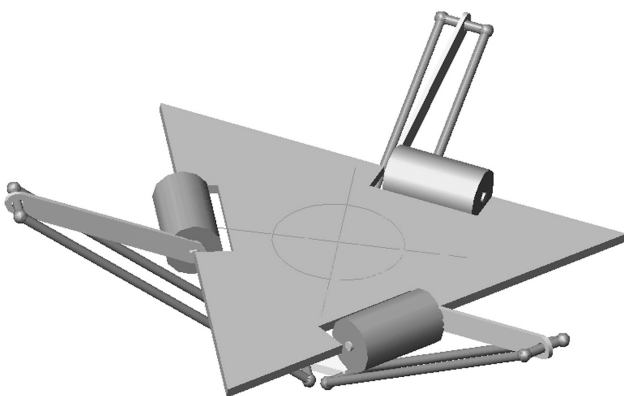

**Fig. 4** Completely contracted configuration of the robot depicting condition (17)

the moving platform and in fact lie entirely along  $y_i$ -axes.

2. Condition (20) also implies that the third column of  $J_p$  is zero. Physically, the posture of the robot again corresponds to when all the limbs  $b_i$  are in the plane of the moving platform. However, they can have both  $x_i$  and  $y_i$  components non-zero. An example is shown in Fig. 5, where  $\theta_{2i} + \theta_{1i} = \pi$ . This situation is depicted by a virtual horizontal plane as the actual relative lengths of  $a_i$  and  $b_i$  prevent reaching that singular configuration.

Conditions (18) and (19) are harder to visualize and we refrain from displaying their figurative representation.

## 5 INTERMEDIATE JACOBIANS AND SINGULARITIES

This section, introduces the idea of intermediate Jacobians that relate the velocity of the end-effector to the time rate of change of the length of a kinematic chain. In order to explain the idea, the closed loop  $OA_iC_iP \subseteq OA_iB_iC_iP$ , which is obtained by ignoring the limbs  $a_i$  and  $b_i$  in the full kinematic chain  $OA_iB_iC_iP$ , is explained and reviewed. The Jacobian analysis of this smaller loop is now carried out. This is the reason to call the corresponding Jacobians as the intermediate Jacobians. The loop equation is

$$\vec{A_iC_i} = -\vec{OA_i} + \vec{OP} + \vec{PC_i} \quad (21)$$

The length  $\overline{A_iC_i}$  is that of the vectorial kinematic chain  $A_iC_i$ . Writing the vector components in the reference frame  $x_iy_iz_i$  and simplifying the resulting

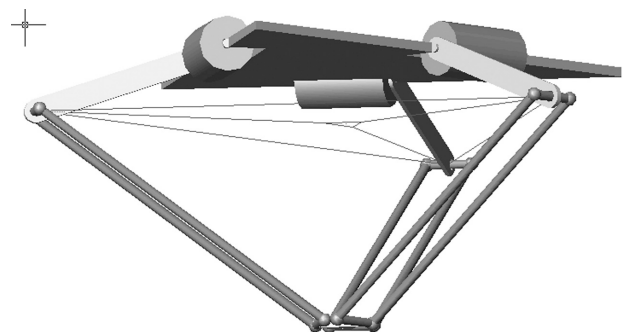

**Fig. 5** The virtual horizontal plane corresponds to condition (20)

equation leads to

$$\begin{aligned} c_i^2 &= c_{x_i}^2 + c_{y_i}^2 + c_{z_i}^2 \\ &= (p_x + (r - R) \cos \phi_i)^2 + (p_y - (r - R) \sin \phi_i)^2 + p_z^2 \end{aligned}$$

where  $c_i = A_i C_i$ . Adopting a more convenient notation in which  $p_x \equiv p_1, p_y \equiv p_2, p_z \equiv p_3$ , a function

$$\begin{aligned} f_i(p_i, c_i) &= (p_1 + (r - R) \cos \phi_i)^2 + (p_2 - (r - R) \sin \phi_i)^2 \\ &\quad + p_3^2 - c_i^2 \end{aligned}$$

can be defined, such that the time differentiation yields

$$\frac{\partial f_i}{\partial p_j} \frac{\partial p_j}{\partial t} + \frac{\partial f_i}{\partial c_j} \frac{\partial c_j}{\partial t} = 0$$

This equation can be readily re-arranged in the following form

$$J_{ij}^p \dot{p}_j = J_{ij}^c \dot{c}_j \quad (22)$$

where the new intermediate Jacobians are defined as

$$J_{ij}^p = \begin{bmatrix} \frac{\partial f_1}{\partial p_1} & \frac{\partial f_1}{\partial p_2} & \frac{\partial f_1}{\partial p_3} \\ \frac{\partial f_2}{\partial p_1} & \frac{\partial f_2}{\partial p_2} & \frac{\partial f_2}{\partial p_3} \\ \frac{\partial f_3}{\partial p_1} & \frac{\partial f_3}{\partial p_2} & \frac{\partial f_3}{\partial p_3} \end{bmatrix}, \quad J_{ij}^c = - \begin{bmatrix} \frac{\partial f_1}{\partial c_1} & \frac{\partial f_1}{\partial c_2} & \frac{\partial f_1}{\partial c_3} \\ \frac{\partial f_2}{\partial c_1} & \frac{\partial f_2}{\partial c_2} & \frac{\partial f_2}{\partial c_3} \\ \frac{\partial f_3}{\partial c_1} & \frac{\partial f_3}{\partial c_2} & \frac{\partial f_3}{\partial c_3} \end{bmatrix} \quad (23)$$

It is preferable to call  $J_{ij}^p$  and  $J_{ij}^c$  direct and inverse intermediate Jacobians because they arise by considering the sub-loop  $OA_i C_i P$  of the full loop  $OA_i B_i C_i P$ , which leads to the conventional definition of the Jacobian matrices. Explicitly evaluating the partial derivatives involved, results in up to a multiplicative factor

$$\begin{aligned} J_{ij}^p &= \begin{bmatrix} c_1 & 0 & 0 \\ 0 & c_2 & 0 \\ 0 & 0 & c_3 \end{bmatrix} \\ J_{ij}^c &= \begin{bmatrix} p_1 + \cos \phi_1 (r - R) & p_2 - \sin \phi_1 (r - R) & p_3 \\ p_1 + \cos \phi_2 (r - R) & p_2 - \sin \phi_2 (r - R) & p_3 \\ p_1 + \cos \phi_3 (r - R) & p_2 - \sin \phi_3 (r - R) & p_3 \end{bmatrix} \end{aligned} \quad (24)$$

Just as mentioned earlier, the singularities of these matrices correspond to the singular positions of the robot. The inverse singularities correspond to

the fact that

$$c_i = 0 \quad \text{for any of the } i \quad (26)$$

This situation arises when one of the kinematic chains is completely shuffled up (a position corresponding to condition (17)). The direct singularities correspond to the condition

$$p_z = 0 \quad (27)$$

or

$$r = R \quad (28)$$

If  $a$  were equal to  $b$ , it is easy to see that condition (27) includes both the conditions (19) and (20). Condition (28) does not owe itself to a certain position or orientation of the manipulator. It is related to its structure because it corresponds to when the dimensions of the moving and the fixed platform become equal. It is a singularity and is sometimes referred to as the architectural singularity [6]. It is a characteristic of the Delta-type robots and has been mentioned in the above reference in the context of a new variation of the Delta robot that can be called RAF-robot. As a confirmation, an analysis of the intermediate Jacobians for the RAF-robot confirms that the results are identical. Note that the conventional Jacobians do not make reference to such singularities. However, cumbersome direct kinematic analysis can be used to confirm the existence of this singularity. Without going into calculational details, the final results of the direct kinematic analysis are

$$\begin{aligned} p_x &= \frac{f_1 - e_1 - e_3 [e_2 f_2 - e_2 e_4 - e_5 f_1 + e_1 e_5 / e_2 e_6 - e_3 e_5]}{e_2}, \\ p_y &= \frac{e_2 f_2 - e_2 e_4 - e_5 f_1 + e_1 e_5}{e_2 e_6 - e_3 e_5}, \\ p_z &= [e_8 - p_x^2 - p_y^2 + 2k_3 p_x - 2s_3 p_y]^{1/2} \end{aligned} \quad (29)$$

where

$$\begin{aligned} k_i &= (R - r) \cos \phi_i, \quad s_i = (R - r) \sin \phi_i, \quad i = 1, 2, 3 \\ e_1 &= k_3^2 - k_1^2 + s_3^2 - s_1^2, \quad e_2 = 2k_1 - 2k_3 \\ e_3 &= 2s_3 - 2s_1, \quad e_4 = k_3^2 - k_2^2 + s_3^2 - s_2^2 \\ e_5 &= 2k_2 - 2k_3, \quad e_6 = 2s_3 - 2s_2 \\ e_7 &= k_3^2 + s_3^2, \quad e_8 = c_3^2 - e_7 \\ f_1 &= c_3^2 - c_1^2, \quad f_2 = c_3^2 - c_2^2 \end{aligned} \quad (30)$$

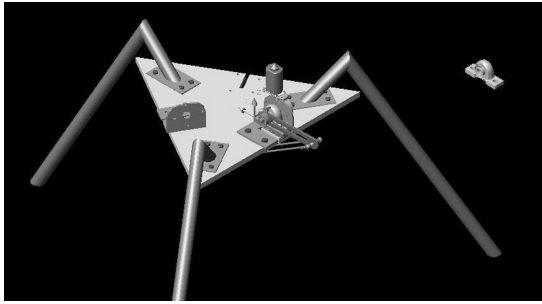

**Fig. 6** A preliminary version of the prototype of the Delta robot in the Mechanical Engineering Department of the Instituto Tecnológico de Morelia, Morelia, México

Moreover,  $c_i$  can be written entirely in terms of  $a$ ,  $b$  and  $\theta_{ij}$  as follows

$$c_i^2 = a^2 + b^2 + 2ab \sin \theta_{3i} \cos \theta_{2i} \quad (31)$$

Equation (29) gives the position of the end-effector in terms of the actuated joint variables. Therefore, it is a set of equations corresponding to direct kinematic analysis. The singular positions corresponding to equation (29) are

$$e_2 = 0, \quad e_2 e_6 - e_3 e_5 = 0 \quad (32)$$

One of the ways to satisfy these conditions is to set  $r = R$ , which is nothing but condition (28). However, the analysis of the intermediate Jacobians is the simplest way to arrive at this singular position.

## 6 CONCLUSIONS

This article presents a detailed Jacobian analysis for the Delta robot, based upon its kinematics and the vector analysis for rotational systems. Employing the technique of the two-part Jacobian developed by Gosselin and Angeles [10], the inverse and forward kinematic Jacobians are evaluated. As a natural advantage, the associated singularities can be classified into two categories: (i) the ones that arise from setting the determinant of the inverse kinematics Jacobian to zero and lie at the boundary of the workspace and (ii) the others that are connected to the direct kinematics Jacobian and lie well inside the workspace region. A new method of identifying these singularities is then introduced using intermediate Jacobians, which are much less intricate to evaluate and contain not only the information found in traditional Jacobian matrices but also describe structural singularities. For practical purposes, the knowledge of these singularities plays an essential role in studying the dynamics and

ultimately the physical manufacturing of the manipulator, Fig. 6.

## REFERENCES

- 1 **Clavel, R.** Delta, a fast robot with parallel geometry. In Proceedings of the 18th International Symposium on Industrial Robots, Lausanne, France, 26–28 April 1988, 91–100.
- 2 **Bonev, I.** Delta parallel robot – the story of success, 2001, available from <http://www.parallemic.org/Reviews/Review002.html>.
- 3 **Callegari, M. and Tarantini, M.** Kinematic analysis of a novel translational platform. *Trans. ASME*, 2003, **125**, 308–315.
- 4 **Di Gregorio, R.** Kinematics of the translational 3-URC mechanism. In Proceedings of the IEEE/ASME International Conference on Advanced Intelligent Mechatronics, Como, Italy, 8–11 July 2001, Vol. 1, pp. 147–152.
- 5 **Joshi, S. A. and Tsai, L. W.** Jacobian analysis of limited-DOF parallel manipulators. *ASME J. Mech. Des.*, 2002, **124**(2), 254–258.
- 6 **Romdhane, L., Affi, Z., and Fayet, M.** Design and singularity analysis of a 3-translational-DOF in-parallel manipulator. *J. Mech. Des.*, 2002, **124**, 419–426.
- 7 **Tsai, L. W. and Joshi, S. A.** Kinematics and optimization of a spatial 3-UPU parallel manipulator. *ASME J. Mech. Des.*, 2000, **122**, 439–446.
- 8 **Tsai, L. W. and Stamper, R.** A parallel manipulator with only translational degrees of freedom. In Proceedings of the ASME Design Engineering Technical Conference, Irvine, CA, USA, 96-DETC-MECH-1152, 1996.
- 9 **Gosselin, C. and Angeles, J.** The optimum kinematic design of a planar three-degree-of-freedom parallel manipulator. *J. Mech. Transm. Automat. Des.*, 1988, **110**(1), 35–41.
- 10 **Gosselin, C. and Angeles, J.** Singularity analysis of closed-loop kinematic chains. *IEEE Trans. Robot. Automat.*, 1990, **6**, 281–290.
- 11 **Gosselin, C. and Sefrioui, J.** Determination of the singularity loci of spherical three-degree-of-freedom parallel manipulators. In Proceedings of the 1992 ASME Design Engineering Technical Conference, DE-1992, **45**, 329–336.
- 12 **Stamper, R. E.** *A three degree of freedom parallel manipulator with only translational degrees of freedom.* PhD Thesis, Department of Mechanical Engineering, University of Maryland, 1997.
- 13 **García, G.** *Análisis de Trayectoria Libres de Colisiones Para Un Manipulador Paralelo de 3 GDL.* Masters Thesis, Instituto Tecnológico de Morelia, Morelia, México, 2004.
- 14 **Di Gregorio, R.** Determination of singularities in delta-like manipulators. *Int. J. Robot. Res.*, 2004, **23**(1), 89–96.
- 15 **Tsai, L. W.** *Robot analysis: the mechanics of serial and parallel manipulators* (John Wiley & Sons, Inc., New York, 1999).