

Block Assembly		DWG #: 0
UNLESS NOTED: 1. Break Sharp Corners Max 1/64 2. All Dimensions: .xxx±0.005 .xx±0.03 3. Drawing not to scale	FILE: block assembly.slddrw	
	QUANTITY: 1	UNITS: Inches
	MATERIAL: Per Part	
Caltech ME 71		
DATE: 4/6/2002	DRAWN BY: M. Grunthaner	

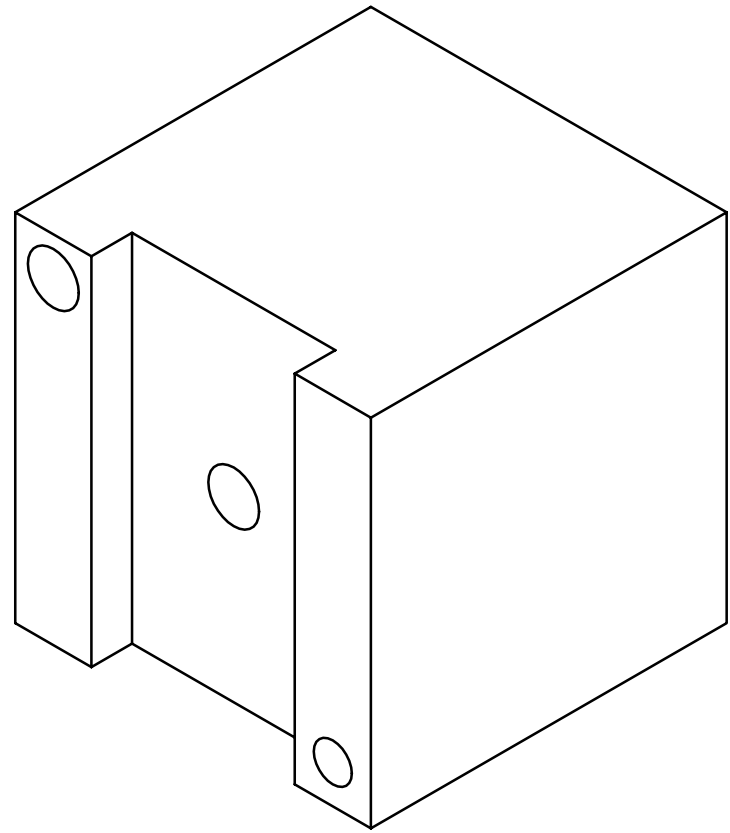

1. Cut to slip-fit with Secondary Block 1.0 inch stock

Primary Block		DWG #: 1
UNLESS NOTED: 1. Break Sharp Corners Max 1/64		FILE: primary block.sldrw
2. All Dimensions: .xxx \pm 0.005 .xx \pm 0.03	QUANTITY: 1	UNITS: Inches
3. Drawing not to scale	MATERIAL: Aluminum Stock	
Caltech ME 71		
DATE: 4/6/2002	DRAWN BY: M. Grunthaner	

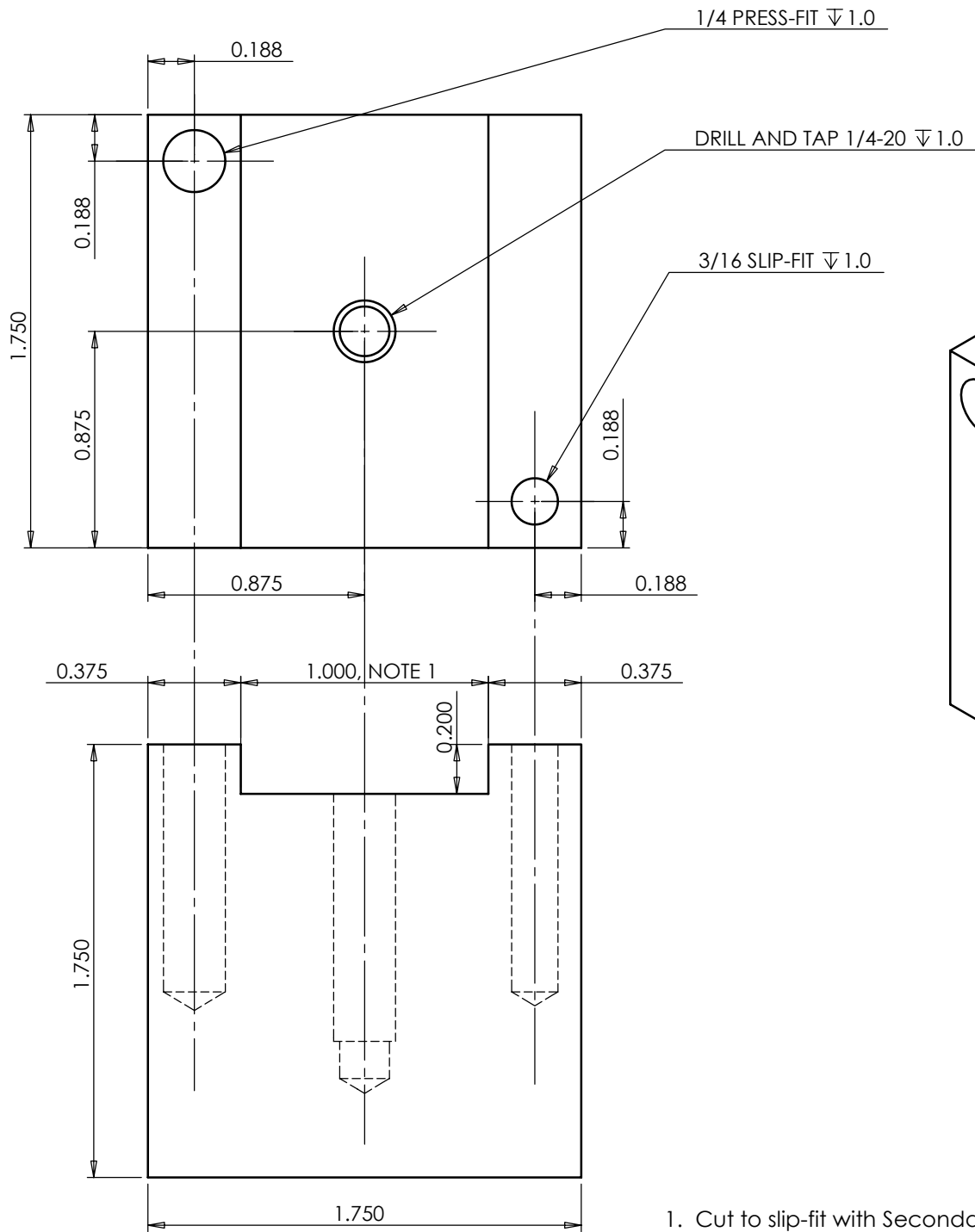
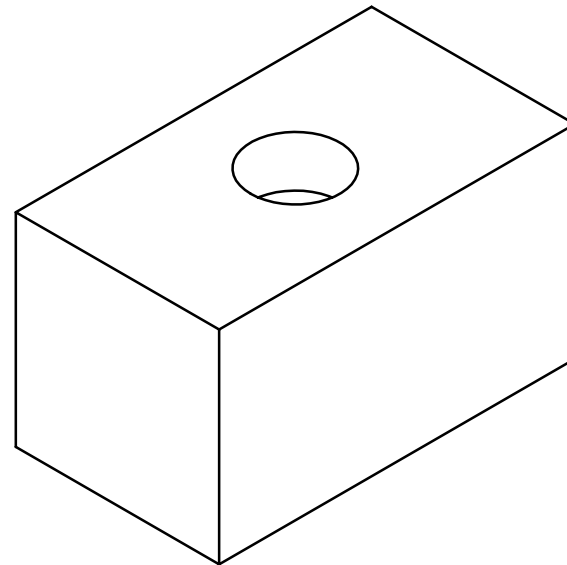
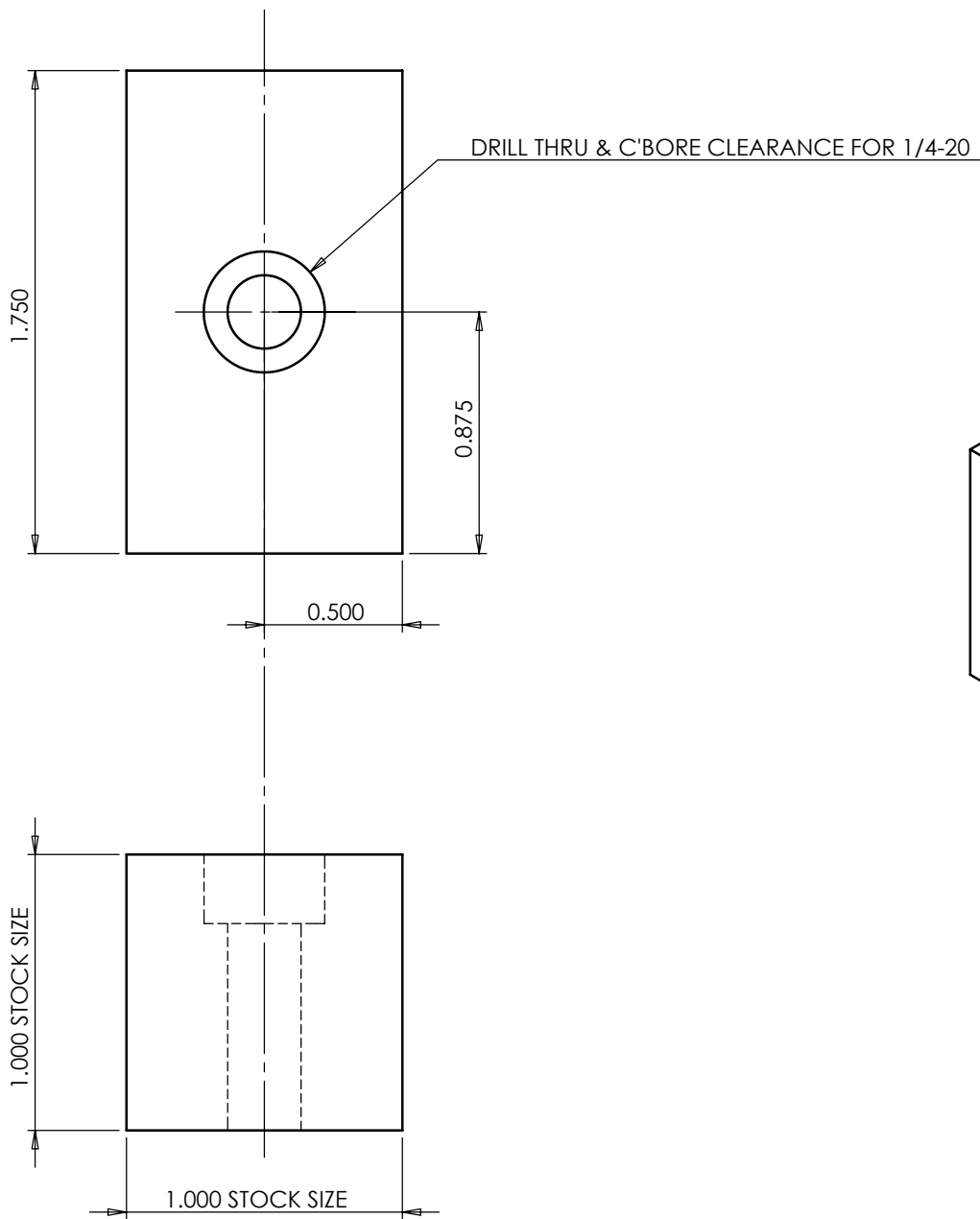

Secondary Block		DWG #: 2
UNLESS NOTED:	FILE:	
1. Break Sharp Corners Max 1/64	secondary block.sldrw	
2. All Dimensions: .xxx±0.005 .xx±0.03	QUANTITY: 1	UNITS: Inches
3. Drawing not to scale	MATERIAL: Aluminum Stock	
Caltech ME 71		
DATE: 4/6/2002	DRAWN BY: M. Grunthaner	